



PanBlast™ Heavy Duty Blast Cabinets –Model PB1500

*“Surface Preparation
Is Our Business”*

PanBlast™ Heavy Duty Suction Blast Cabinets are highly efficient, general purpose, industrial usage blast cabinets, designed for use with a wide range of abrasive blasting media.

PanBlast™ PB1500 Cabinet Standard Features:

- * Cyclone type abrasive separator to clean the abrasive while the system is in use
- * Safety door interlock to prevent the blast system from operating while the door is open
- * Integral dry cartridge reverse pulse dust collector to keep the cabinet ventilated and visually clear for the operator
- * Heavy duty wear resistant rubber gloves which protect the operator and provide long wear life
- * Quick change laminated glass viewing window which requires no tools to replace
- * Fully adjustable abrasive feed tee which allows the system to operate on virtually any abrasive media size and type
- * Compressed air regulator and gauge to provide for the blasting pressure to be varied for differing applications
- * High performance PanBlast™ Delta Suction Gun to provide faster and more effective cleaning
- * Standard air blow down gun to remove dust from components after blasting



PanBlast™ PB1500 with optional track and trolley assembly

PanBlast™ PB1500 Cabinet Common Applications:

- * De-scale and de-rust metal surfaces
- * Remove paint and powder coating
- * De-burr, de-flash and remove sand from castings and moldings
- * Provide decorative finishes to stainless steel, aluminium and other non-ferrous metals
- * Etching of glass, stone and metals
- * Removal of release agents and contamination from molds

Commonly Used Abrasives:

- * FastBlast™ Chilled Iron Grit
- * PanaGrit™ Cast Steel Grit
- * QuickCut™ Aluminium Oxide
- * BrightBlast™ Glass Beads
- * EnviroGrit™ Garnet

Blast Pots & Cabinets - Control Valves - Abrasive Control Valves - Blast Nozzles - Nozzle Holders & Couplings - Helmets & Breathing Air Filters

PB1500 Cabinet Assembly -

Stock Code	BEC-CA-PB-0007
Fan Size	1.5Kw (2hp) 415V 50Hz 3 Phase
Cabinet Light	2 x 36 Watt 240V 50hz 1 Phase
Compressed Air Req'd	85m ³ /hr (50cfm)@550kPa (80psi)
Work Door Opening	1055mm (41 3/8") Wide 855mm (33 3/8") High

Optional Items -

Stock Code	Description
BAC-CA-PB-0212	250kg Track & Trolley Assembly
BAC-CA-PB-0243	350mm x 375mm Tumble Basket
BAC-CA-PB-0040	300mm x 325mm Tumble Basket
BAC-CA-PB-0244	Fixed Turntable
BAC-CA-PB-0241	Fan Silencer Kit
BAC-CA-PB-0292	Noise Reduction Kit
BAC-CA-PB-0279	Rubber Lined Cabinet
BAC-CA-PB-0277	Blast Gun Stand
BAC-CA-PB-0455	Foot Pedal Guard

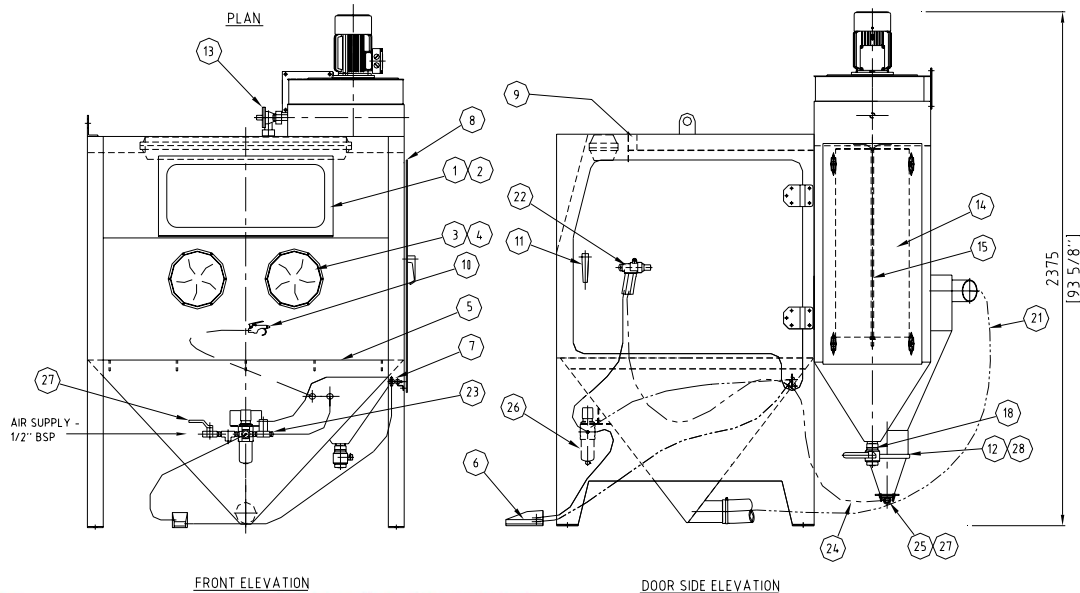
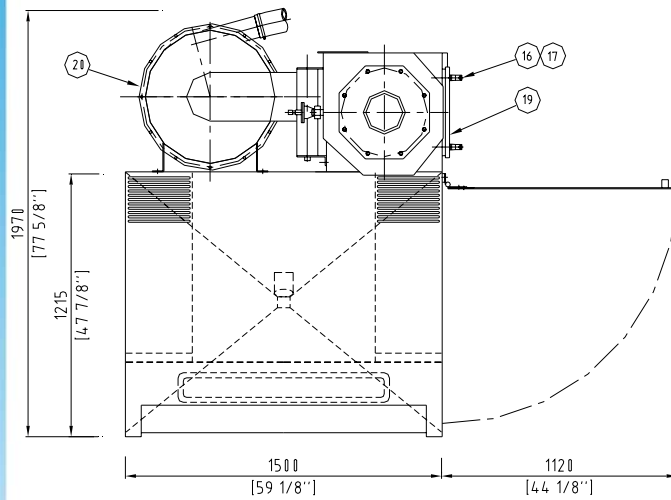

PB1500 Parts List -

Item	Stock Code	Description	Qty
1	BAC-CA-PB-0137	Cabinet Window	1
2	BAC-CA-PB-0141	Window Seal	2
3	BAC-GL-PB-0003	Cabinet Gloves	1 pr
4	BAC-CA-PB-0157	Glove Entry Rings	2
5	BAC-CA-PB-0318	Cabinet Mesh Floor	1
6	BAC-CA-PB-0086	Blast Foot Pedal	1
7	BAC-CA-PB-0087	Work Door Safety Valve	1
8	BAC-CA-PB-0319	Work Door Seal	1
9	BAC-CA-PB-0324	Air Entry Filter	2
10	YAC-CA-PB-0145	Blow Down Gun	2
11	YAC-CA-PB-0138	Work Door Latch	1
12	YAC-FN-PB-0041	Toggle Clip	2
13	BAC-DC-PB-0007	Dust Collector Pulse Valve	1
14	BAC-DF-PB-0005	Filter Cartridge Size 3	1
15	BAC-DC-PB-0032	Filter Cartridge Hanger Rod	1
16	YAC-CA-PB-0146	Dust Collector Door Handle	4
17	YAC-CA-PB-0205	Dust Collector Door Handle Latch	4
18	BAC-PF-PB-0008	Dust Collector Drain Valve	1
19	BAC-CA-PB-0436	Dust Collector Door Seal	1
20	BAC-CA-PB-0282	Rubber Lined Cyclone	1
21	BAC-CA-PB-0430	Recovery Hose	1
22	BAC-BG-PB-0057	Delta Blast Gun	1
23	BAC-RC-PB-0142	Door Pilot Safety Valve	1
24	BAC-HB-PB-0021	Abrasive Hose	3.5m
25	BAC-CA-PB-0220	Feed Tee Assembly	1
26	BAC-AF-PB-0047	Air Pressure Regulator/Filter	1
27	BAC-PF-PB-0001	Air Shut Off Valve	1
28	BAC-CA-PB-0353	Abrasive Hopper Seal	1

Blast Pots & Cabinets - Control Valves - Abrasive Control Valves - Blast Nozzles - Nozzle Holders & Couplings - Helmets & Breathing Air Filters - Blast Suits

www.pan-abrasives.com
 Email - pagroup@pan-abrasives.com

Pan Abrasives Group
 Australia - Ph. 613 9303 3801 - Fax. 613 9308 7933
 China - Ph. 86 21 6317 8833 - Fax. 86 21 6317 9231
 Malaysia - Ph. 603 5637 3822 - Fax. 603 5637 2822
 Singapore - Ph. 65 6861 6988 - Fax. 65 6861 0919

In the interests of on-going product development, all data and information is subject to change without prior notice.

03-16-003