

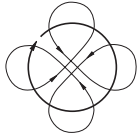

Dynorbital-Spirit®



3/8"
(10 mm)
Diameter Orbit

For Aggressive Sanding



Look for **ORANGE** Throttle Lever

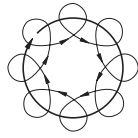

3/16"
(5 mm)
Diameter Orbit

For General Sanding



Look for **GREY** Throttle Lever



3/32"
(2 mm)
Diameter Orbit

For Ultra-Fine Sanding



Look for **BLACK** Throttle Lever

Non-Vacuum

- Includes low profile, premium urethane weight-mated sanding pad.
- Optional vacuum conversion kits available, to easily convert non-vacuum tool to self-generated or central vacuum tool (see page 11).

Pad Diameter Inch (mm)	3/8" Orbit Models	3/16" Orbit Models	3/32" Orbit Models
3 (76 mm)	59100	59105	59110
3-1/2 (89 mm)	59000	59015	59030
5 (127 mm)	59005	59020	59035
6 (152 mm)	59010	59025	59040

Tune-Up Kit: No. 96510



Model 59020

See page 12 /
for **NEW ORANGE**
Sanding Pads!

Self-Generated Vacuum

- Includes low profile, premium urethane weight-mated sanding pad.
- Model 58054 includes 56320 Pad for Mesh Abrasives (see page 12, 15).
- Ready for connection to optional portable self-contained dust collection system.

Pad Diameter Inch (mm)	3/8" Orbit Models	3/16" Orbit Models	3/32" Orbit Models
3 (76 mm)	59103	59108	59113
3-1/2 (89 mm)	59003	59018	59033
5 (127 mm)	59008	59023/58054	59038
6 (152 mm)	59013	59028	59043

Tune-Up Kit: No. 96510



Model 59023

Portable Dust Collection System
(Optional - See Page 16)

Central Vacuum

- Includes low profile, premium urethane weight-mated sanding pad.
- Has 1" outside diameter vacuum port, for easy connection to central vacuum system.

Pad Diameter Inch (mm)	3/8" Orbit Models	3/16" Orbit Models	3/32" Orbit Models
3 (76 mm)	59104	59109	59114
3-1/2 (89 mm)	59004	59019	59034
5 (127 mm)	59009	59024	59039
6 (152 mm)	59014	59029	59044

Tune-Up Kit: No. 96510



Model 59024

See page 11 for complete specifications of each Dynorbital-Spirit® model.



Light-to-Medium Duty Sander Offers “D3” Advantages!

NEW! Compact Grip Size

Compact, ergonomic design has been reduced in size by 5%. Ideal for operators with smaller hands, and for use in vertical applications!

NEW! Single-Piece Locking Ring

Allows easier assembly and provides tighter seal.

Perfectly Balanced Sanding Pad

Ask for the **ORANGE!**

Perfectly-balanced, weight-mated sanding pad with exclusive **one-piece hub design**. Dynabrade premium urethane pads offer smoother operating performance and minimal vibration.

- 3" (76 mm) – 75 grams
- 3-1/2" (89 mm) – 80 grams
- 5" (127 mm) – 100 grams
- 6" (152 mm) – 130 grams

Auto-Recess Throttle Lever

Lever recesses into housing grip when depressed, eliminating pressure-point on operator's palm. Lever is made from composite material to insulate against cold air. Lever is color-coded to identify tool orbit (see page 8).

Comfort Platform

(U.S. Patent No. D610,428)

Provides additional hand and wrist support, enhancing operator comfort. Also offers protection against cold air exhaust.

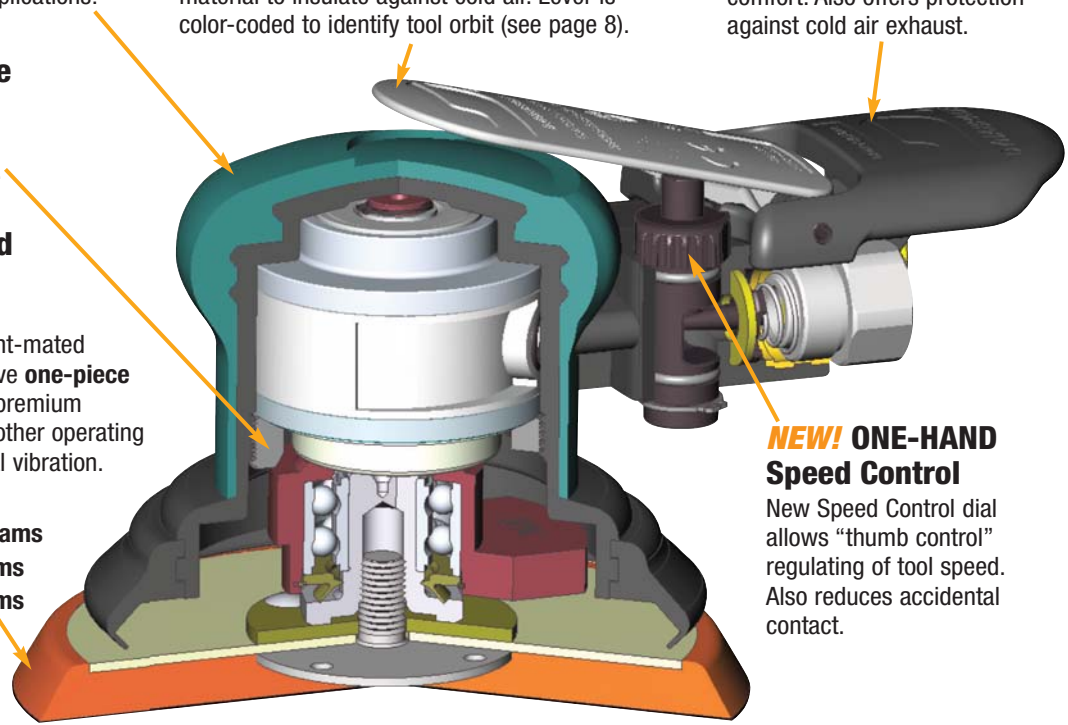

NEW! ONE-HAND Speed Control

New Speed Control dial allows “thumb control” regulating of tool speed. Also reduces accidental contact.

NEW! Enhanced Vacuum Capabilities

Vacuum port diameter is increased by 110%, allowing maximum capture of dust and debris!



5" (127 mm) Dia. Vacuum Shroud shown.

NEW! “Stays-Tight” Threaded Muffler

Muffler cap is now threaded, to remain firmly attached to tool during use.



Patented Bearing Protection

“V-Seal” bearing seal protects balancer shaft bearing from sanding residue, resulting in longer tool life.



“Top Hat” Seal

Protects front motor bearing from sanding residue, and holds in bearing lubrication while keeping out contaminants.

